

BEVEL GEAR DRIVES

SERVICE MANUAL

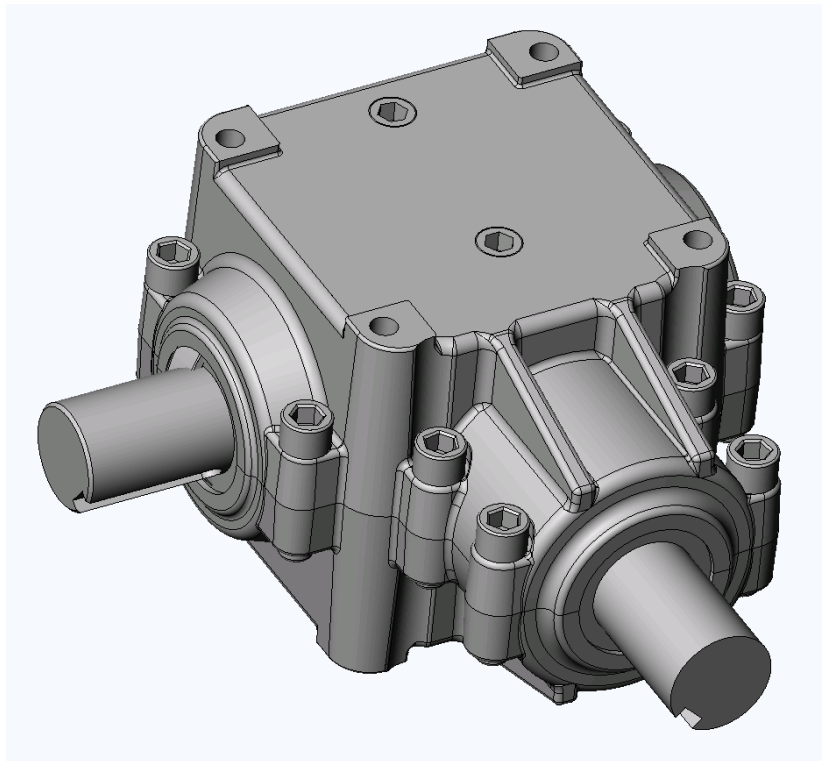

SUPERIOR GEARBOX COMPANY

PO Box 645, Stockton, Missouri, 65785 1-800-346-5745
417-276-5191 FAX 417-276-3492 superiorgearbox.com

BEVEL GEAR DRIVES

SERVICE MANUAL

SAFETY PRECAUTIONS

CAUTION

Please read this entire document prior to operating the gear drive. Gear drive failure and / or injury to operators may be caused by improper installation, operation or maintenance.

The buyer shall be responsible to:

- Determine if the gear drive selected is mechanically adequate for the chosen application and to verify that published catalog capacities are not exceeded.
- Ensure that all connected rotating parts in the system are free from critical torsional or any other type vibration.
- Eliminate any obstruction to cooling airflow when mounting the gear drive. Also consider any accumulation of external debris which could reduce cooling airflow over the unit during operation.

INSTALLATION

Gear drives must be mounted on a rigid, structurally sound baseplate. Flatness within 0.010 in. is recommended. Ensure that gear drive mounting pads rest evenly on the baseplate. The use of shims may be required to avoid housing distortion which could alter the gear mesh or cause premature bearing failure.

The gear drive may be driven by direct coupling, flexible coupling, or V-belt drive. Couplers should require only a light force to install. The driveline must be accurately aligned within the equipment manufacturer's requirements to limit operating loads and minimize thrust loads on the gear drive shaft. V-belt drives must be mounted close to the housing to minimize excessive overhung loading which could result in early bearing or shaft failures. Sheaves must fit correctly. At installation, a tight forced fit could move the shaft from its normal position and cause internal damage. A loose fit could induce excessive vibration during operation and cause shaft damage or breakage.

WARNING

When mounting the gear drive, the buyer is responsible to properly determine the quality or grade of fastener, thread engagement, load carrying capacity, and torque requirements.



SUPERIOR GEARBOX COMPANY

PO Box 645, Stockton, Missouri, 65785 1-800-346-5745
417-276-5191 FAX 417-276-3492 superiorgearbox.com

BEVEL GEAR DRIVES

SERVICE MANUAL



WARNING

The buyer is responsible to provide protective shields over all external rotating parts, couplers, or shaft extensions mounted on or with the gear drive. Eye shields and protective clothing must be worn when installing or maintaining the gear drive and operating system.

Initial operation should be carried out under *no-load* conditions. Before applying power to the gear drive installation, review the following:

- Check tightness of mounting bolts.
- Check for proper oil level in gear drive.
- Be certain that tools, debris, etc., are clear from rotating parts.
- Rotate shafts by hand. If they do not rotate freely, check for uneven mounting, coupling misalignment, or excessive belt tension.

If all tests are satisfactory, make connections to shaft(s), ensure that all safety devices are in place, and begin operation.

LUBRICATION

All gear drives are factory tested prior to shipment. They include the correct amount of oil unless specified by the customer to be shipped dry. Shaft bearings are splash lubricated and partially submerged in oil when the gear drive is mounted horizontally. After installation, remove the dipstick and verify correct oil level. If no dipstick is provided, determine level by any appropriate method. In general, the oil level should be approximately half the depth of the gear drive (to the parting line) for horizontal mounting, or to the shaft centerlines, if mounted other than horizontally.

CAUTION

Prior to operation, make sure the gear drive contains the correct amount of oil. If under-filled or over-filled, damage to the gear drive or injury to personnel may result.

Approved Lubricants:

- For gear drives operating in an ambient temp of 15° to 125° F, and oil temperatures to 200° F, Mobilube HD 80W-90 (or equivalent) is recommended.
- For gear drives requiring start-up in an ambient temp below 15° F or operating continuously above 200° F, Mobilube synthetic SHC 75W-90 (or equivalent) is recommended.

CAUTION

Do not combine synthetic with non-synthetic oils in the gear drive.



SUPERIOR GEARBOX COMPANY

PO Box 645, Stockton, Missouri, 65785 1-800-346-5745
417-276-5191 FAX 417-276-3492 superiorgearbox.com

BEVEL GEAR DRIVES

SERVICE MANUAL

MAINTENANCE

WARNING

Disconnect power prior to any maintenance and do not bypass or inactivate any safety or protective device. Lock out and tag the power supply to prevent unexpected application of power.

Routinely inspect mounting bolts, couplers, or other power transmitting devices to ensure all parts are firmly anchored. Keep shafts and vent plugs (when included) clean to prevent foreign particles from entering seals or housing. Inspect daily for any oil leaks and any unusual noises. Inspect weekly for end play in shafts. Inspect belt drive tension after the first ten hours of operation and periodically thereafter.

Check the oil level every 24 hours of operation. Change the oil when the gear drive has been in service for 50 hours. Routine oil change intervals will vary for each particular installation depending on the severity of the environment. Normal changes should occur between 250 and 1000 hours of operation. The longest life at continuous service will be realized when the oil temperature does not exceed 200° F. For oil substitutions, or for high input speeds, contact Superior Gearbox.

WARNING

Do not change or add oil while the gear drive is running. Damage to the gear drive or injury to personnel may result. The gear drive housing, oil, plugs, and associated components may reach high temperatures and cause severe burns. Use *extreme* care when servicing the gear drive.

LONG TERM STORAGE or INACTIVITY

When a gear drive is stored, prior to initial installation, or following removal from service, the following steps are recommended:

- Fill completely with oil. Attach a prominent notice that the gear drive must be drained and refilled to the proper level prior to start-up.
- Apply a rust preventive to the externally exposed shafts.
- Store the gear drive in a temperature and humidity controlled area.
- Periodically, rotate the shafts by hand.

If the gear drive is in service but inactive for 60 days or more, periodically rotate the shafts by hand and check the oil level prior to start-up.



SUPERIOR GEARBOX COMPANY

PO Box 645, Stockton, Missouri, 65785 1-800-346-5745
417-276-5191 FAX 417-276-3492 superiorgearbox.com

BEVEL GEAR DRIVES

SERVICE MANUAL

GEAR DRIVE DISASSEMBLY

Gear drive disassembly should be accomplished in a clean, dry, and well lighted area. For a general representation of gear drive parts, see the generic gear drive illustration on page 7. For specific model or assembly information, contact Superior Gearbox.

WARNING

During operation, the gear drive housing, plugs, and oil may reach high temperatures. To avoid severe burns after removing from operation, allow sufficient time for the gear drive to cool to ambient prior to disassembly.

1. Drain the oil by removing a bottom drain plug (refer to the assembly drawing).
2. Remove all cap screws. To separate the housings, use a rubber or plastic mallet to strike the top side of the stub shaft while holding the top housing firmly.
3. With the top housing removed, hold the stub shaft with one hand and strike the bottom housing adjacent to the front bearing to allow the stub shaft / gear assy to be removed. To remove the cross shaft, hold it with one hand and strike the housing adjacent to the nearest bearing.
4. If the bearings must be replaced, use *extreme* care to prevent any damage to the shaft seal area when using press equipment during removal and re-installation. The seal surface finish must be 8 to 25 micro-inch. Both the bearing and seal areas should be polished after bearing removal, however, do not reduce the shaft diameter by excessive polishing or burnishing.
5. If gear replacement is required, and the gears are installed with keys, use *extreme* care during removal and replacement to prevent any damage to the shaft seal area. If the gears are press - fit onto the shafts (Perma-Fit), the gear / shaft assembly must be replaced at the factory.
6. Oil seals must be discarded and replaced each time the gear drive is disassembled, to prevent oil leakage.



SUPERIOR GEARBOX COMPANY

PO Box 645, Stockton, Missouri, 65785 1-800-346-5745
417-276-5191 FAX 417-276-3492 superiorgearbox.com

BEVEL GEAR DRIVES

SERVICE MANUAL

GEAR DRIVE REASSEMBLY

CAUTION

The reassembly area should be clean, dry, well lighted and free from oil, grease, or any debris which could contaminate the gear drive oil, bearings or seals.

1. Prior to assembly, all mating surfaces must be clean and free from oil or debris.
2. Install the cross shaft assembly (shaft, gear, bearings and seals) into the bottom housing. Use *extreme* caution when installing seals onto shafts to prevent any seal damage. Ensure that the seal is installed correctly, with the spring toward the bearings. Align seals and bearings with the appropriate machined pockets. Push into place or tap the shaft lightly with a mallet to seat (do not tap bearings).
3. Install the stub shaft assembly in a similar manner, meshing gear teeth before seating into place. Ensure that both shafts turn freely. Apply several drops of oil onto both of the stub shaft bearings. Apply only at the cup / cone interface on the **top** of each bearing. This requirement is to provide sufficient lubricant to the stub shaft bearings during the initial start-up of the gear drive.
4. Remove all residue from the mating surfaces of both top and bottom housings. Wipe dry with a clean cloth. Apply a small **continuous** bead of Loctite #598 Surface Sealant on the mating surface of the bottom housing from seal to seal. At each tapped hole, the bead must be applied between the hole and the inside edge of the housing. Take care that the sealant does not flow down into the cast oil groove adjacent to the stub shaft.
5. Assemble the top housing onto the bottom housing, taking care to align the seals with both machined pockets. Tap the corners of the top housing with a mallet to seat the mating surfaces. Install cap screws. Torque 5/16-18 screws to 17-21 ft-lbs, 3/8-16 screws to 35-40 ft-lbs, and 1/2-13 screws to 67-73 ft-lbs.
6. Replace the drain plug into the bottom housing. Fill with the proper amount of oil through the oil fill hole in the top housing. Replace the fill plug. This completes the reassembly.



SUPERIOR GEARBOX COMPANY

PO Box 645, Stockton, Missouri, 65785 1-800-346-5745
417-276-5191 FAX 417-276-3492 superiorgearbox.com

BEVEL GEAR DRIVES

SERVICE MANUAL

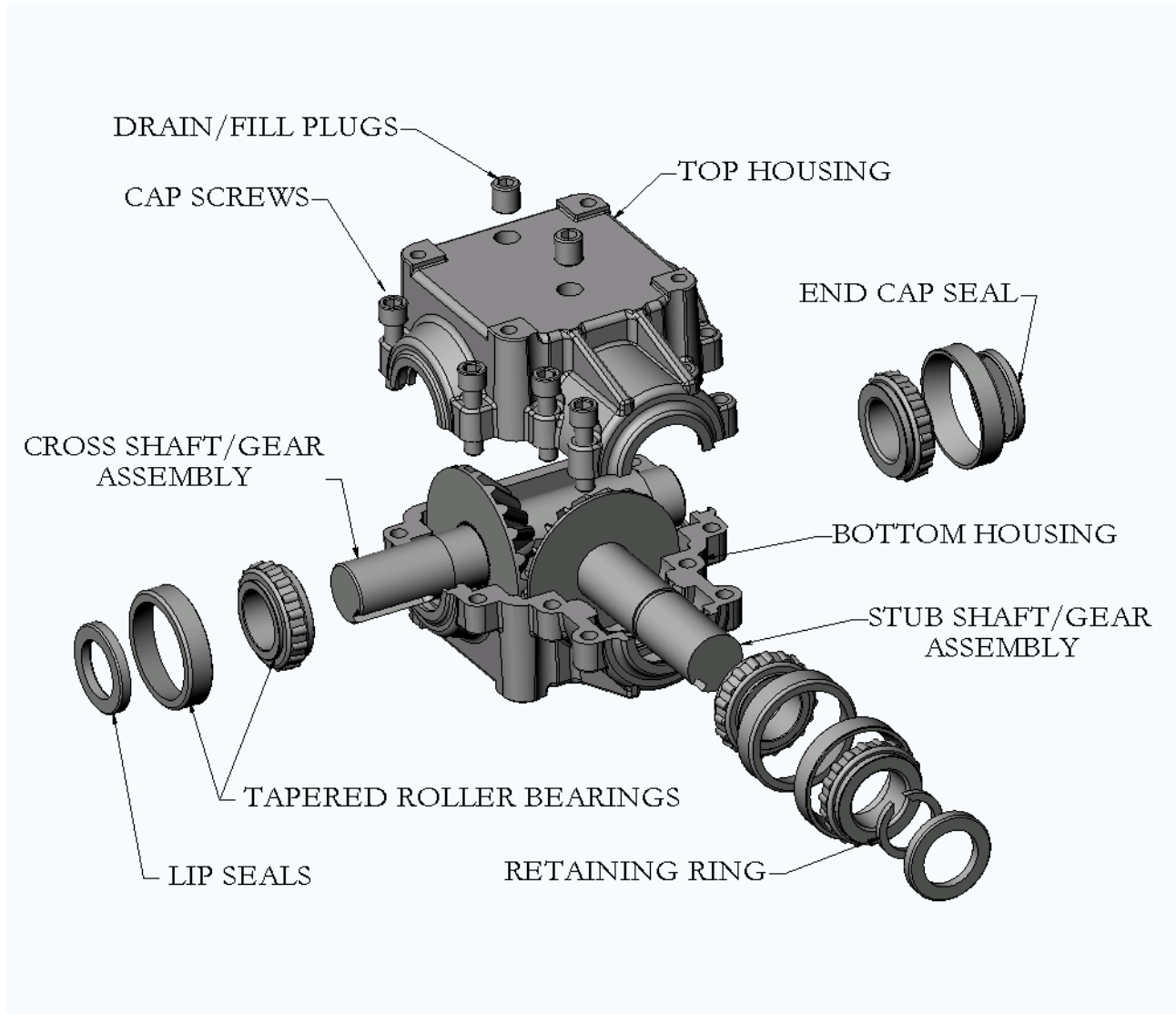

GENERIC GEAR DRIVE ILLUSTRATION



SUPERIOR GEARBOX COMPANY

PO Box 645, Stockton, Missouri, 65785 1-800-346-5745
417-276-5191 FAX 417-276-3492 superiorgearbox.com

BEVEL GEAR DRIVES

SERVICE MANUAL

TROUBLESHOOTING

SYMPTOM	PROBABLE CAUSE	REMEDY
Breather leaking	Incorrect oil level RPM too high Unit running hot	Check oil level Reduce RPM Provide additional cooling
Unit running hot	Incorrect oil level Inadequate air flow Excessive RPM or load Contaminated oil Failing bearings	Check oil level Provide additional cooling Change to synthetic oil Replace oil Replace bearings
Unusual noise	Gear mesh changed Excessive external load Failing bearings or gears	Inspect driveline Inspect belt tension Replace bearings or gears
Oil leaking	Failing seals Mating surfaces	Replace seals Rebuild gear drive
Vibration	Loose mounting bolts Loose couplers, pulleys Failing bearings or gears Driveline misalignment	Inspect / tighten Inspect / tighten Replace bearings or gears Correct misalignment



SUPERIOR GEARBOX COMPANY

PO Box 645, Stockton, Missouri, 65785 1-800-346-5745
417-276-5191 FAX 417-276-3492 superiorgearbox.com