

# Right Angle Geardrive Request for Quotation

The below guide will assist with the proper selection of the gearbox required for your application. Please fill out this worksheet with as much detail as possible and send a copy to our sales team with any additional documentation that may be useful during selection.

## Contact Information:

Company Name: \_\_\_\_\_ Contact Name: \_\_\_\_\_

Contact Number: \_\_\_\_\_ Email: \_\_\_\_\_

Preferred Contact Method:  Phone  Email Quantity to be Quoted: \_\_\_\_\_

### Series(s) Needed:

- R100 - 1" Shafts Standard
- R200 - 1" Shafts Standard
- R400 - 1.25" Shafts Standard
- R500 - 1.375" Shafts Standard
- R600 - 1.75" Shafts Standard
- R700 - 1.75" Input/2.75" Output Shafts Standard
- R700 Iron - 1.75" Input/2.75" Output Shafts Standard
- R800 - 1.75" Shafts Standard
- R800 Iron - 1.75" Shafts Standard
- R20A series for Grain Augers/Elevators

### Ratio:

*Ratio specified with the #1 shaft as the input  
(Use table to determine available standard ratios based on chosen series)*

- 1:1 Miter
- 1.1:1 Reducer
- 1.18:1 Reducer
- 1.35:1 Reducer
- 1.43:1 Reducer
- 1.5:1 Reducer
- 1.86:1 Reducer
- 2:1 Reducer
- 1:1.1 Increaser
- 1:1.18 Increaser
- 1:1.35 Increaser
- 1:1.43 Increaser
- 1:1.5 Increaser
- 1:1.86 Increaser
- 1:2 Increaser
- 2.92:1 Reducer
- Custom Gear Ratio \_\_\_\_\_

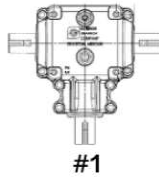

### Standard Catalog Ratio Availability by Series

Ratio Type	Ratio	R100	R200	R400	R500	R600	R700	R800	R20A
Miter	1:1	✓	✓	✓	✓	✓		✓	✓
Reducer	1.1:1	✓							
Reducer	1.18:1					✓		✓	
Reducer	1.35:1			✓	✓	✓		✓	
Reducer	1.43:1	✓							
Reducer	1.5:1	✓	✓	✓	✓	✓		✓	
Reducer	1.86:1					✓		✓	
Reducer	2:1		✓	✓	✓	✓			
Reducer	2.92:1						✓		
Increaser	1:1.1	✓							
Increaser	1:1.18					✓		✓	
Increaser	1:1.35			✓	✓	✓		✓	
Increaser	1:1.43	✓							
Increaser	1:1.5	✓	✓	✓	✓	✓		✓	
Increaser	1:1.86					✓		✓	
Increaser	1:2		✓	✓	✓	✓			

### Number of Output Shafts:

- 1
- 2
- 3\*

\*Not available for R800 Series

### Shaft Rotation:

(See image for reference)

- A
- B
- C
- D
- E
- F
- G
- H
- I
- J
- K
- L
- Custom Rotation Needed

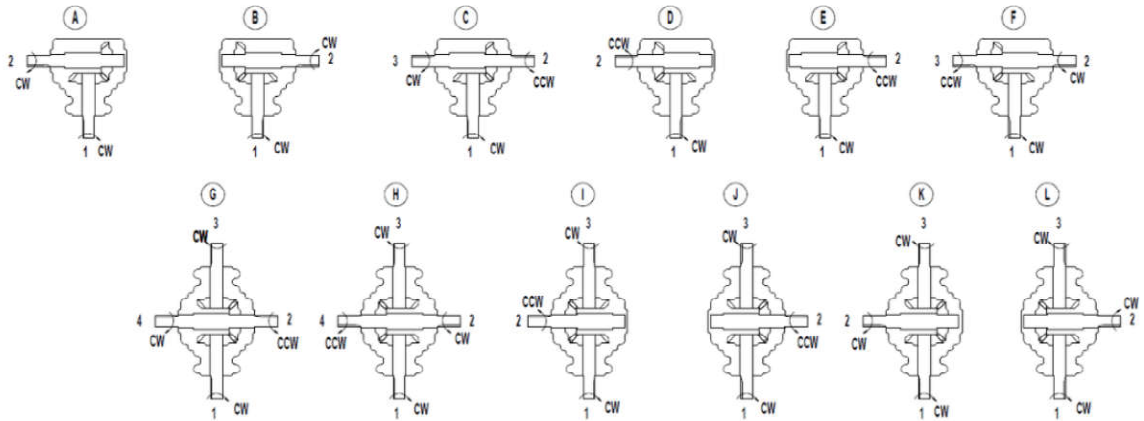

Describe any additional requirements, modifications to the standard options or custom design needs:

---



---



---