

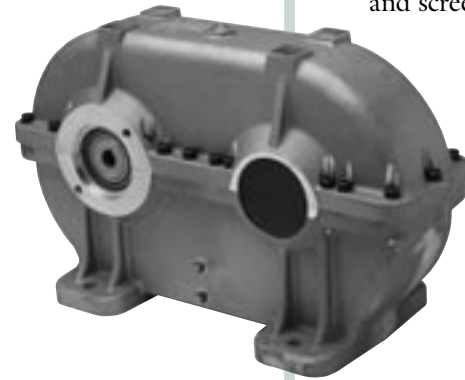

# Shaker S10 Series

Applications include vibratory trenchers, vibrating conveyors and various sorting and screening devices.



**Features:**

- Two-piece aluminum housing for high strength, corrosion resistance and thermal capacity
- Precision machined for exact gear mesh and bearing preload
- 100% leak tested
- High strength, cost effective ductile iron gears are cast with integral weights
- High strength alloy shafts
- Tapered roller bearings provide increased load capacity and bearing life
- The S10 Series weighs approximately 80/90 lbs.

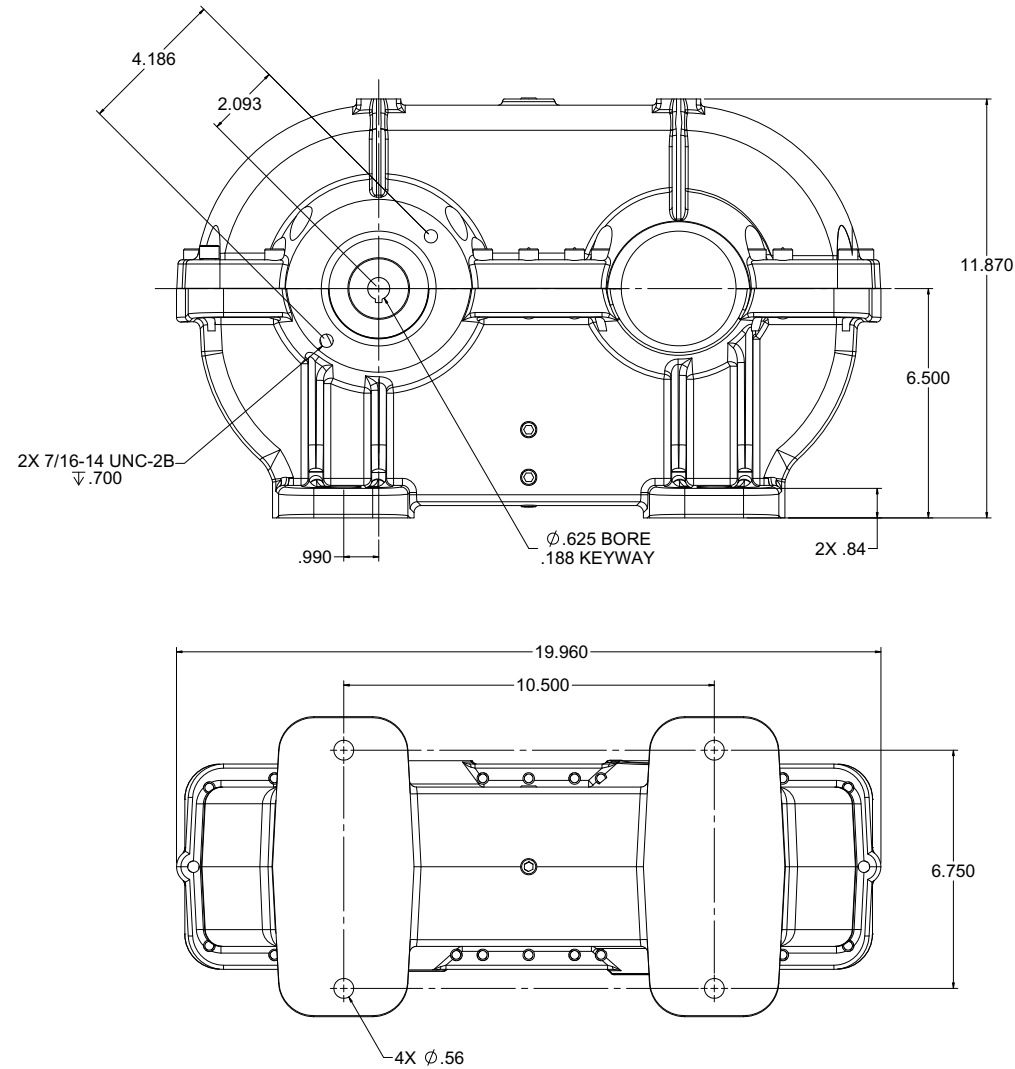

Contact Superior Gearbox for your special requirements.